

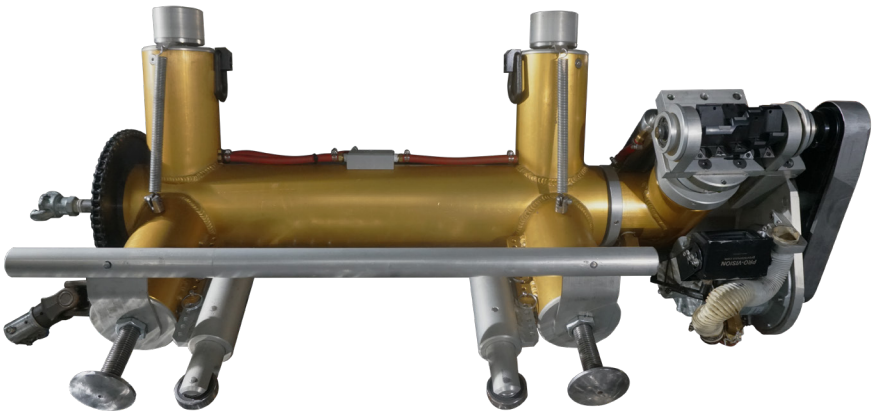

Manufacturer of the

# **BEADTRIMMER™**

**HDPE FUSION BEAD REMOVAL TOOLING**



## **OPERATIONS MANUAL**

### **Mega-Large BeadTrimmer™ (MLBT)**

**R&L MANUFACTURING, INC.**

215 East Reserve Street

Suite 104; PMB B12

Vancouver, WA 98661

(360) 833-9194

[www.RLMFG.com](http://www.RLMFG.com)

This page intentionally left blank

# BEADTRIMMER™ OPERATIONS MANUAL

## Table of Contents

### Mega-Large BeadTrimmer™

Warranty .....	2
Mega-Large BeadTrimmer™ Overview .....	3
Station Set-Up .....	4
Handle Package Set-Up .....	5

### MLBT Head

Features .....	6
Set-Up .....	9

### MLBT Control Box

Features .....	10
Set-Up .....	12

### MLBT Systems Check

Pre-Systems Check .....	13
Systems Check .....	14

### MLBT Operation

Operators (2) .....	15
Operation .....	16

### Maintenance

Maintenance .....	17
-------------------	----

#### VIDEO

See the Mega-Large BeadTrimmer™ in action at  
[www.RLMFG.com](http://www.RLMFG.com)



Manufacturer of the

**BEADTRIMMER™**  
HDPE FUSION BEAD REMOVAL TOOLING

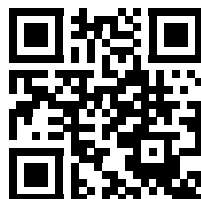

# BEADTRIMMER™ OPERATIONS MANUAL

## Mega-Large BeadTrimmer™ Warranty

### WARRANTY

1. Equipment Warranty. Company warrants all Equipment to be free from defects in material or workmanship under normal use and service for a period of ninety (90) days from the date of delivery. All repair covered by this warranty must be done at Company's factory, or other such warranty repair facilities of Company as designated by Company unless Company specifically directs that this service be performed at another location. Any defect corrected within ninety (90) days and found to be within this scope of the warranty will be repaired by Company and all charges for labor and material, will be borne by Company. If it is determined that either no fault exists in Company, or the damage to be repaired was caused by negligence of Distributor, its agents, employees or customers, Distributor agrees to pay all charges associated with each such repair. THIS CONSTITUTES THE SOLE WARRANTY MADE BY COMPANY EITHER EXPRESSED OR IMPLIED. THERE ARE NO OTHER WARRANTIES EXPRESSED OR IMPLIED WHICH EXTEND BEYOND THE FACE HEREOF, HEREIN, INCLUDING THE IMPLIED WARRANTIES OF MERCHANTABILITY AND FITNESS FOR A PARTICULAR PURPOSE. IN NO EVENT SHALL COMPANY BE LIABLE FOR ANY INCIDENTAL OR CONSEQUENTIAL DAMAGES AND DISTRIBUTOR'S REMEDIES SHALL BE LIMITED TO REPAIR OR REPLACEMENT OF NONCONFORMING UNITS OR PARTS. THE WARRANTY AND TERMS AS EXPRESSED HEREIN SHALL NOT APPLY TO ANY CLAIMS BY ANY END USER AND/OR CONTRACTOR, AND COMPANY MAKES NO OTHER WARRANTY EXPRESSED OR IMPLIED TO SUCH USER, INCLUDING, BUT NOT LIMITED TO, ANY CLAIM FOR BACK CHARGES, DOWN TIME, OR OTHER INTERRUPTION OF WORK.

2. Misuse of Equipment. Any tampering, misuse or negligence in handling or use of Equipment renders the warranty void. Further, the warranty is void if, at any time, Distributor attempts to make any internal changes to any of the components of the Equipment; if at any time the power supplied to any part of the Equipment exceeds the rated tolerance; if any external device attached by Distributor creates conditions exceeding the tolerance of the Equipment; if any time the serial number plates is removed or defaced; or Distributor fails to follow any terms set forth within any training or operation guides provided by Company. OPERATION OF THE EQUIPMENT THAT RENDERS THIS WARRANTY VOID WILL BE DEFINED TO INCLUDE ALL OF THE POSSIBILITIES DESCRIBED IN THIS PARAGRAPH, TOGETHER ON ANY PRACTICE WHICH RESULTS IN CONDITIONS EXCEEDING THE DESIGN TOLERANCE OF THE EQUIPMENT.

3. Indemnity. The Distributor agrees to hold the Company free and harmless from any and all claims, damages, and expenses of every kind or nature whatsoever (a) arising from acts of the Distributor; (b) as a direct or indirect consequences of termination of this Agreement in accordance with its terms; or (c) arising from acts of third parties in relation to products sold to the Distributor under this Agreement, including, but not limited to execution of liens and liens and security interests by third parties with respect to any such products.

# MEGA-LARGE BEADTRIMMER™

## BEADTRIMMER™ MLBT OVERVIEW

R&L Manufacturing's BeadTrimmer™ tooling is designed to remove the interior fusion bead in **High Density Polyethylene (HDPE) fused pipe only**. The Mega-Large BeadTrimmer™ series offers **three sizes** to accommodate a range of large diameter pipe.

Each BeadTrimmer™ has an adjustable cutting range to accommodate varying Interior Diameters (ID) due to Dimension Ratio (DR) and pipe wall thickness.

### MLBT-30

Cutting range: 24" (609mm) to 28" (711mm)

### MLBT-36

Cutting range: 28" (711mm) to 36" (914mm)

### MLBT-54

Cutting range: 36" (914mm) to 52" (1320mm)

The pneumatic MLBT requires compressed air (not included) to operate. Use clean, dry, regulated compressed air at **82 CFM @ 100 PSI**. Never use oxygen, carbon dioxide, combustible gases, or any other bottled gas as a power source for this tool.

MEGA-LARGE HEAD SIZE		CUTTING RANGE		SHIPPING WEIGHT & SIZE			
PN #	NOM. PIPE SIZE	MINOR (ID)	MAJOR (ID)	LENGTH	WIDTH	HEIGHT	WEIGHT
MLBT-30	30" (762mm)	24" (609mm)	28" (711mm)	60"	34"	25"	400 lbs
MLBT-36	36" (914mm)	28" (711mm)	36" (914mm)	60"	44"	45"	500 lbs
MLBT-54	54" (1372mm)	36" (914mm)	52" (1320mm)	60"	44"	45"	550 lbs

INCLUDED ITEMS		SHIPPING WEIGHT & SIZE			
PN #	DESCRIPTION	LENGTH	WIDTH	HEIGHT	WEIGHT
ML-OB	Operator Control Box	54"	36"	43"	460 lbs
ML-WR	60' Wiper Rod Set	98"	9"	9"	70 lbs
HP-51	51' Handle Package	98"	9"	9"	107 lbs

Unit includes Mega-Large BeadTrimmer™ head, Operator Control Box, 60' Wiper Rod Set, (3) Wipers, and 51' Handle Package.

## STATION SET-UP

### CAUTION!

Heavy Equipment. Mega-Large BeadTrimmer™ head weighs over 200 lbs. Use caution when handling and operating.



- 1. Mega-Large BeadTrimmer™ Head**  
Position BeadTrimmer™ head on the ground, near the end of pipe.
- 2. Handle Package & Wiper Rod Set**  
Construct and connect 51' Handle Package to MLBT head on the ground (pg. 5). Construct 60' Wiper Rod Set and set aside.
- 3. Control Box**  
Position the Control Box adjacent to the MLBT head and Handle Package, near end of pipe. Face the opening of the Control Box and Air Hose Reels towards the pipe end. Allow enough clearance to insert and operate the MLBT.
- 4. Compressed Air Supply**  
Position Air Compressor (supplied by user) near Compressed Air Supply line from Control Box. Air requirements 82 CFM @ 100 PSI.

## HANDLE PACKAGE SET-UP

All BeadTrimmer™ heads require a Handle Package to operate. The Standard Handle Package provides 51' (15.5m) of reach and includes:

**(7) 7'9" Torque Tubes, (1) 4'6" Torque Tube, (1) 3' Torque Tube, (1) 18" Torque Tube, (7) Unions with Pins, (1) Crosshead.**



### STEP 1

Use Unions and Pins to connect Torque Tubes to required length. If necessary, combine Coupler Support Sleeves to strengthen connections (pg. 14).

### STEP 2

Secure the Crosshead onto one end of the assembled Torque Tubes using a Wheel Screw. Slide the 18" Torque Tube into the Crosshead and tighten down with thumbscrew.

### STEP 3

Using an Allen wrench, secure Centralizing Disk approximately 7' (2m) to 10' (3m) from open end of assembled Torque Tubes.

### STEP 4

Secure BeadTrimmer™ head to open end of assembled Torque Tubes using a Pin or Wheel Screw.

## MLBT HEAD FEATURES

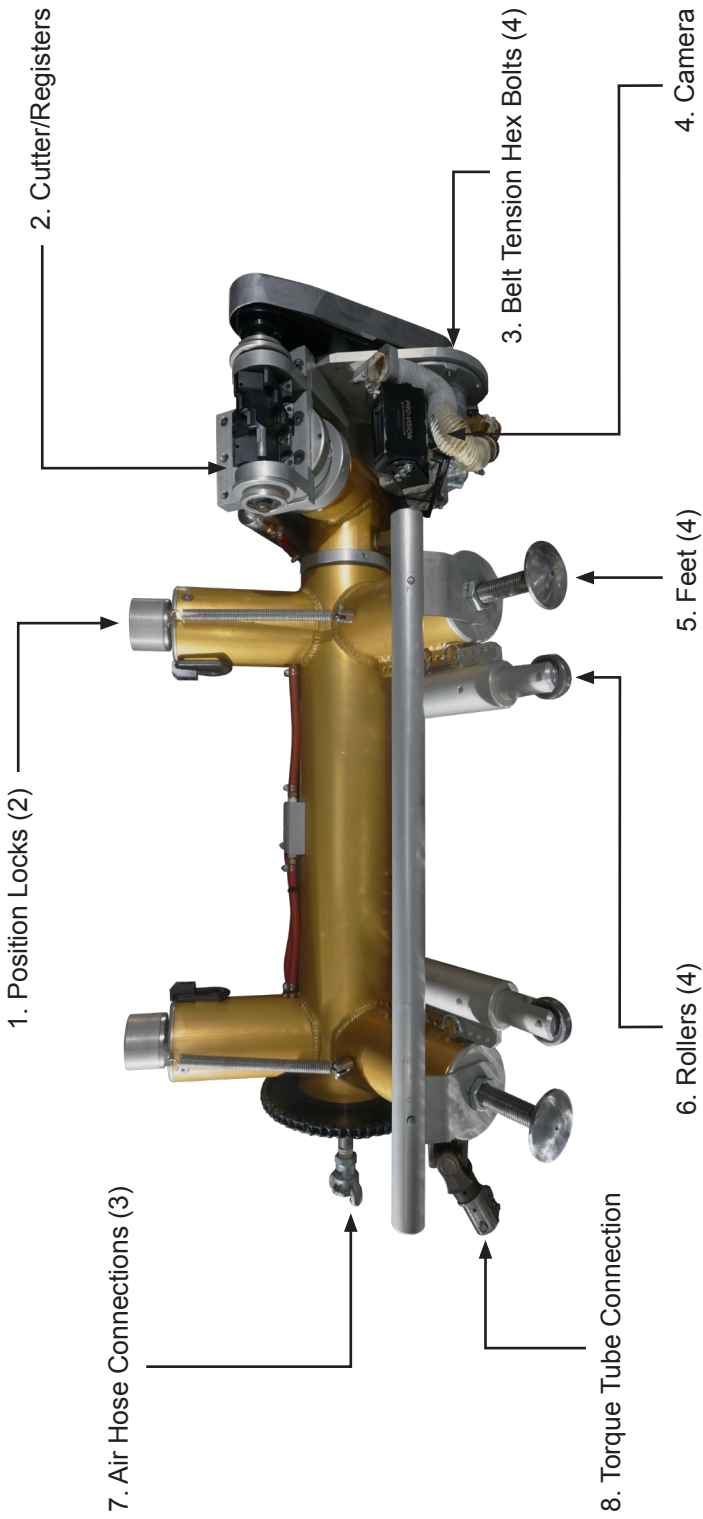



## MLBT HEAD FEATURES

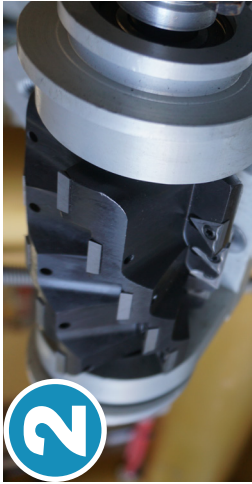
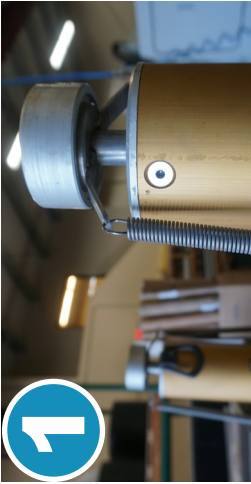

1. Position Locks (2)

2. Cutter/Registers

3. Belt Tension Hex Bolts (4)

4. Index Arm

5. Feet and Rollers (4)

6. Air Hose Connections

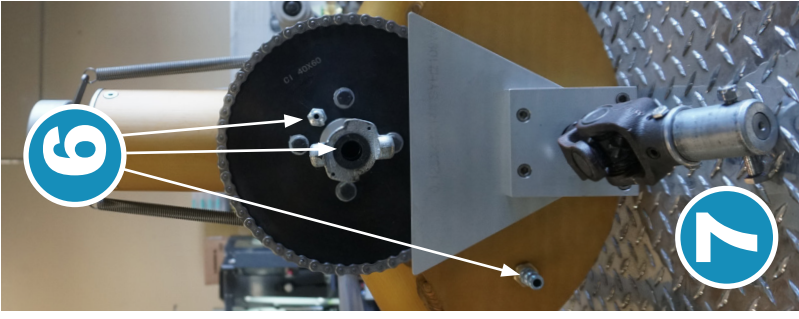

7. Torque Tube Connect

8. Camera



## MLBT HEAD SET-UP

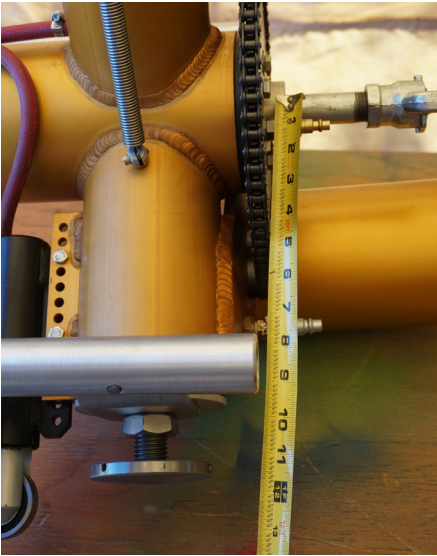

### FEET ADJUSTMENT

Measure from center of MLBT unit to end of Feet. Adjust all four Feet to match radius of interior pipe wall.

Tighten Hex Nut to secure.



### ROLLER ADJUSTMENT

Rollers should be set approximately 1/2" past the Feet. Adjust and secure all four Rollers using the Cotterless Hitch Pin.

## MLBT HEAD SET-UP

### ATTACH AIR HOSE REELS

In the Control Box, 150' of hose is provided in each reel. The reeled 1/4" quick release, 3/8" quick release, and 3/4" Chicago fitting hose connects to MLBT. Compressed air source connects to 3/4" Chicago fitting hose on side of Control Box.

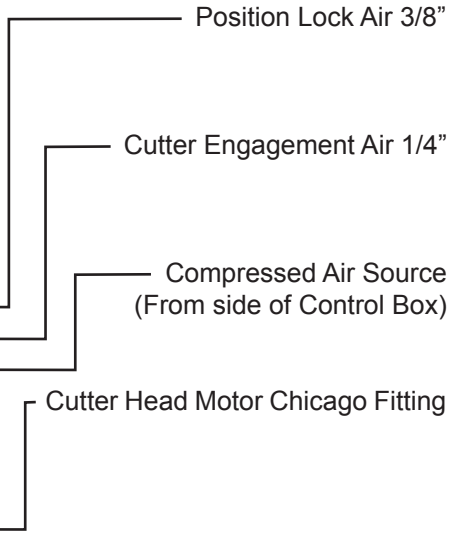

Cutter Engagement Air 1/4"

Cutter Head Motor Chicago

Position Lock Air 3/8"

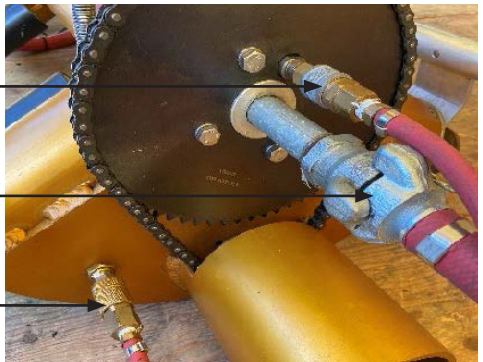

### CAMERA BATTERY

Secure and connect Camera Battery. Camera Batteries (4) and Chargers (4) are located in Side Box within Control Box. Turn Battery ON to SYNC with Camera Monitor.

## CONTROL BOX FEATURES



2



3



4

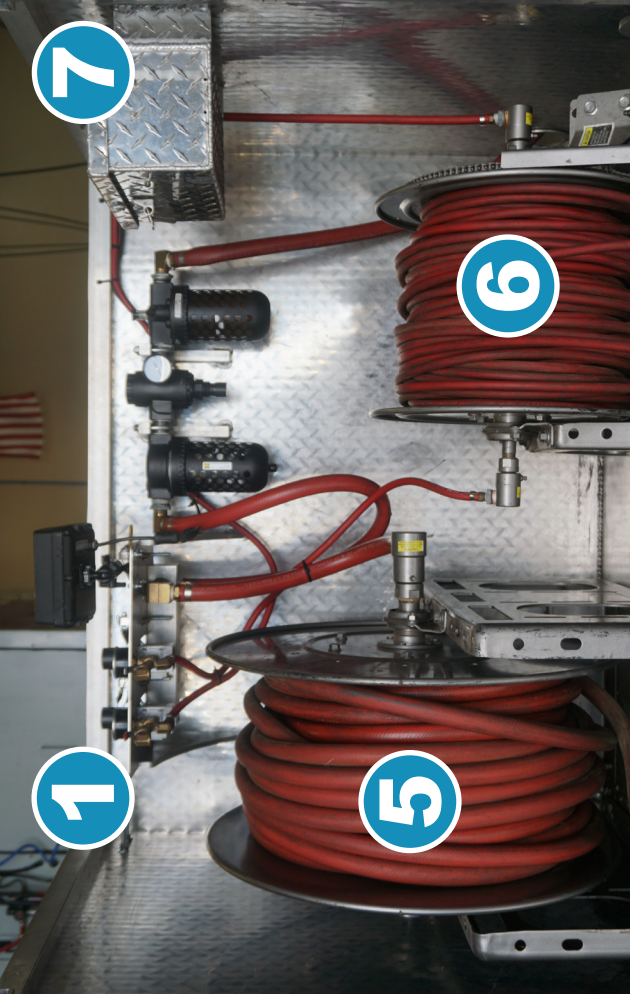

1

5

6

7

1. Control Panel

2. Camera Monitor

3. Bleed Off Valves (2)

4. Oil Water Separator

5. 3/4" Air Hose Reel

6. 1/4" and 3/8" Quick Release Air Hose

7. Side Box

## CONTROL PANEL FEATURES



1. Position Lock ON/OFF

2. Cutter Head Motor  
ON/OFF

3. Cutter Engagement  
ON/OFF

4. Camera Monitor

5. Pressure Gauge (2)

6. Bleed Off Valve (2)

## CONTROL BOX SET-UP



### 1. Control Panel

All controls should be LOCKED in the OFF position.

### 2. Bleed Off Valve (2)

Bleed Off Valves should be in the CLOSED position.

### 3. Camera Monitor

Camera Monitor and Monitor Battery are stored in Side Box for transport. Attached Camera Monitor to Control Board and connect to Monitor Battery. Turn Monitor Battery ON to SYNC with Camera.

### 4. Air Oil Separator and Oiler

Set Air Oil Separator 1/4 to 1 full revolution from OFF position. Keep oil FULL. Refill using SAE 10W motor oil (can use food grade oil if needed). Remove all water before operating.

### LOCK OUT / TAG OUT

Be sure all controls on Control Panel are OFF and LOCKED before connecting compressed air. CLOSE Bleed Off Valves.

### 5. Compressed Air Supply

Connect air compressor to Control Box using Chicago Fitting on Compressed Air Supply line. Minimum air requirements to operate is 82 CFM @ 100 PSI.

## PRE-SYSTEMS CHECK

A Pre-Systems Check is advised before every Mega-Large BeadTrimmer™ Systems Check and operation. A Pre-Systems check is a visual inspection of the MLBT head, Control Box, and Air Hose Connections.

### SAFETY!

Wear appropriate clothing and personal protective equipment including eye/ear protection and gloves, while operating.



#### Inspect Cutter Head

Check for broken carbide inserts. Rotate/replace as necessary.



#### Check Belt Tension, Tension Bolts & Drive Chain

Inspect tension of all screws/nuts/bolts, Tension Belt and Drive Chain



#### Feet & Rollers Adjusted

Feet should be adjusted to the interior diameter of the pipe. Rollers should extend past feet by 1/2".



#### Power Camera & Camera Monitor

Power and SYNC Camera and Camera Monitor. A fully charged battery will last approximately 6 hours.



#### Bleed Off Valves Closed

Make sure Air Hose Reels are properly connected and both Bleed Off Valves are in the CLOSED position.



#### Air Oil Separator

Remove all water before operation. Oil should be full.

## SYSTEM CHECK

Following a successful Pre-Systems Check, perform a Live Air Systems Check. The Mega-Large Bead Trimmer™ head should be on the ground, with the Cutter facing up. Stay clear of engaged Cutter head while performing Live Air System Check and during operation.

### START UP SEQUENCE:

# 1-2-3

#### FIRST

Turn Position Lock Control #1 to ON position.

#### SECOND

Turn Cutter Head Control #2 to ON position.

#### THIRD

Turn Cutter Engagement Control #3 to ON position.

### SHUT DOWN SEQUENCE:

# 3-2-1

#### FIRST

Turn Cutter Engagement Control #3 to OFF position.

OPEN Bleed Off Valve to Cutter Engagement

#### SECOND

Turn Cutter Head Control #2 to OFF position.

#### THIRD

Turn Position Lock Control #1 to OFF position.

OPEN Bleed Off Valve to Position Lock



## MLBT OPERATORS (2)

The Mega-Large BeadTrimmer™ (MLBT) requires a minimum of two (2) Operators to operate. Once the MLBT head is inside the pipe, Operator #1 will position behind the Control Panel, and Operator #2 will be operating the Handle Package T-Handle at the end of the pipe. More personnel may be required to lift the MLBT head in and out of the pipe end, or to help manage Air Hose lines during operation.



### OPERATOR #1

Operator #1 manages the Control Panel and monitors bead removal process through the wireless video feed. Operator #1 is positioned behind the Control Panel.

### OPERATOR #2

Operator #2 rotates the MLBT head using Torque Tubes and T-Handle, included in Handle Package. Operator #2 is positioned at the end of the pipe.

## MLBT OPERATION

After Live Air Systems Check, Operator #1 and Operator #2 lift MLBT head into pipe end. Using connected Handle Package, push MLBT head down pipe until stopped by fusion bead. Adjust into proper position using live Camera feed.

**DO NOT attempt to remove a HOT fusion bead.**

Proper cooling time must be observed before removing the bead.

## MLBT OPERATION

### OPERATOR #2

Rotate Cutter head to upright position and hold firmly onto Handle Package T-Handle.

### OPERATOR #1

Confirm fusion bead is centered on Cutter through the Camera Monitor.

### Initiate Start Up Sequence: 1-2-3

### OPERATOR #2

1. Once engaged, slowly rotate MLBT Cutter head **COUNTERCLOCKWISE** to remove fusion bead.

The rotation differential between T-Handle and Cutter head is 7-1. Continue slowly rotating **COUNTERCLOCKWISE seven rotations for one complete rotation on the Cutter head.**

2. Once fusion bead is removed, slowly rotate Cutter head **CLOCKWISE** one full rotation for **FINISH CUT.**

### OPERATOR #1

### Initiate Shut Down Sequence: 3-2-1

### OPERATOR #2

With help, retract MLBT from pipe and set aside. Use Wiper Rod set to remove plastic shavings.

## MAINTENANCE

The Mega-Large BeadTrimmer™ head and Control Box require routine maintenance before and after daily operations.



- Lubricate through Motor Engagement air line at the end of the day to prevent corrosion.

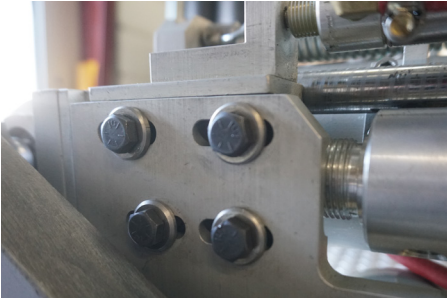

- Inspect and tighten all nuts and bolts before operation.



- Inspect tension of Tension Belt and Drive Chain before operation.



- Remove all water from Air Water Oil Separator before and after operation.

This page intentionally left blank